

ANT-A72GA-TW-N Antenna

USER GUIDE

The ANT-A72GA-TW-N is an active antenna designed to operate at the GPS L1 and L2 frequencies, 1575.42 and 1227.60 MHz. The antenna is aircraft certified for navigation. This guide provides the basic information you need to install and begin using your new antenna.



ADDITIONAL EQUIPMENT REQUIRED

- A device with an antenna input port that both receives the RF signal and provides 2.5 to 24.0 VDC to the antenna is required to set up the ANT-A72GA-TW-N. (NovAtel GPS receivers provide the necessary power through their antenna RF connectors.)
- Coaxial cable with a male TNC connector

INSTALLING THE ANTENNA

Both the input DC power and the output RF signal flow over a single coaxial cable that is connected to the unit's TNC female connector.

The antenna can be attached to a surface by means of an ARINC-743 Bolt Pattern. Four screws pass through the housing of the antenna.

Install the antenna as follows:

1. The antenna is supplied with an o-ring. Place it in the o-ring groove of the antenna base.
User-supplied o-ring grease can be used to hold the o-ring in the groove during installation.
2. Pre-drill the mounting holes and the connector hole on the surface, see the Mechanical Drawings section of this guide for details on the ARINC-743 mounting pattern.

3. Attach the antenna to the surface using the four mounting screws supplied. The o-ring compresses and creates a seal between the surface and the antenna.

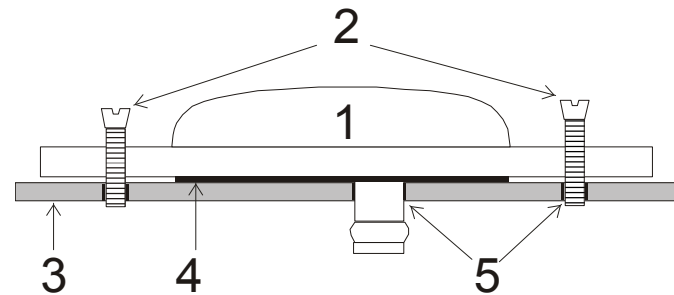

Ref. #	Description	Ref.#	Description
1	Antenna	4	O-ring
2	Countersink screws	5	Pre-drilled mounting holes
3	Mounting surface		

4. Remove the dust cap from the antenna's TNC connector.
5. Attach the male TNC connector of the coaxial cable to the antenna's TNC connector.

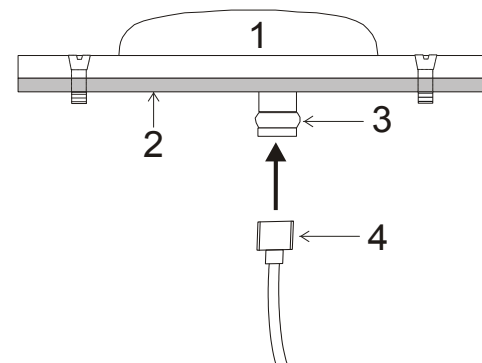

Ref. #	Description
1	Antenna screwed into place
2	Surface
3	TNC connector
4	Coaxial cable

6. Attach the other end of the coaxial cable to the antenna input port of the receiving device, which must provide power as detailed in the *SPECIFICATIONS* section of this guide. All NovAtel GPS receivers provide the necessary power through their antenna RF connectors.

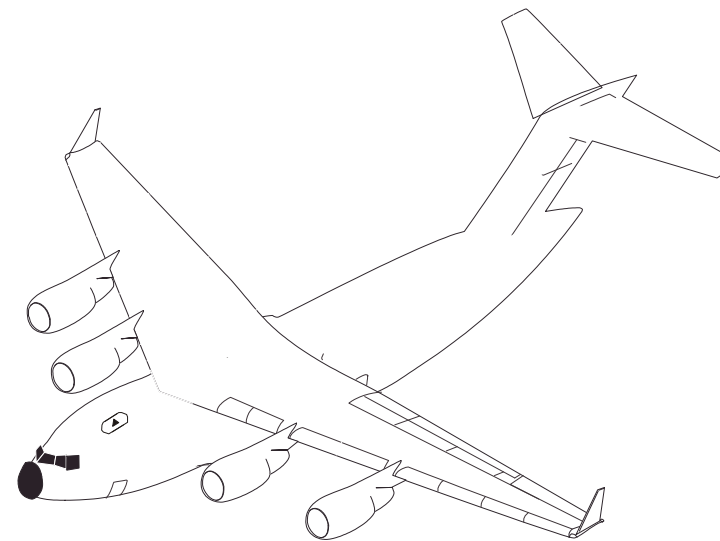

The graphic above shows examples of where the ANT-A72GA-TW-N antenna may be placed on an aircraft or vehicle (not to scale).

ANTENNA CARE

The ANT-A72GA-TW-N is designed to withstand the elements, including rain, snow, and dust. However, to ensure your antenna performs optimally, keep the radome clean and brush off any ice and snow. In addition, ensure the TNC connector remains clean and dry and replace the dust cap when a cable is not connected.

L1 ELEVATION GAIN PATTERN

Max = 4.71dB

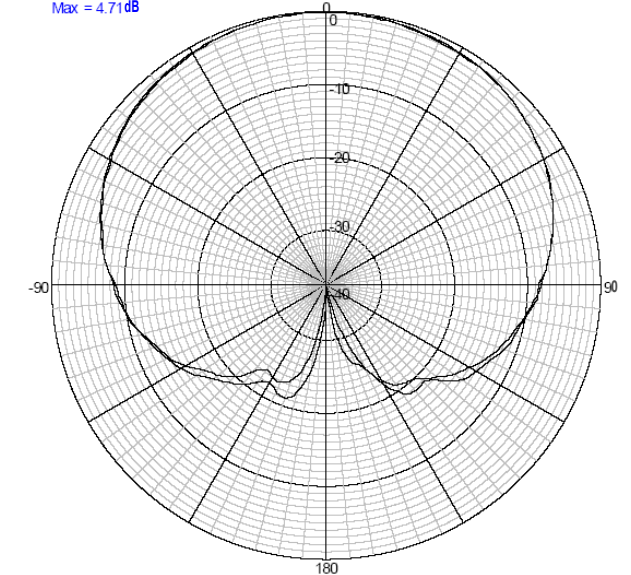

L2 ELEVATION GAIN PATTERN

Max = 3.36 dB

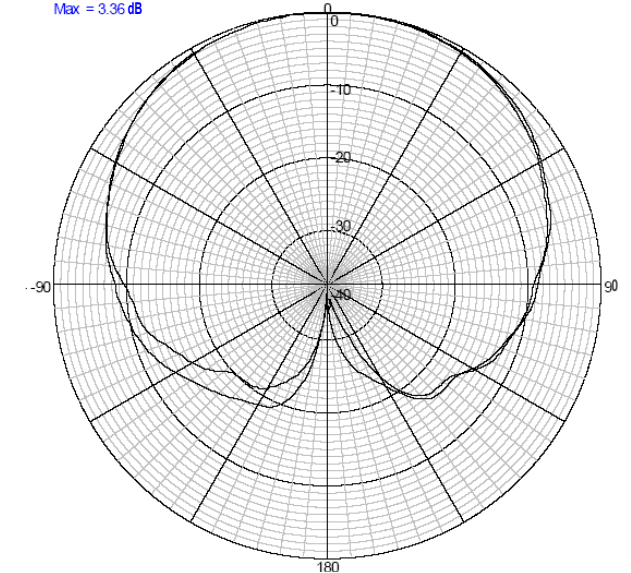

SPECIFICATIONS

RF	
3 dB pass band (typical)	L1: 1575.42 ±13 MHz L2: 1227.60 ±13 MHz
Out-of-band rejection (typical)	> 40 dBc
Gain at zenith ($\theta = 90^\circ$) (min)	L1: +4.7 dBic L2: +3.3 dBic
Gain roll-off (zenith to horizon)	L1: +6.5 dB L2: +7.1 dB
LNA gain (typical)	31/33 ±2 dB
Polarization	Right-hand circular
Noise figure (typical)	3.0 dB
Nominal impedance	50 Ω
VSWR	≤ 1.5 : 1
POWER	
Input voltage	2.5 - 24.0 VDC
Current (typical)	35 mA
PHYSICAL	
Radome Size	5.6 cm (2.20") x 8.6 cm (3.40")
Weight	198 g (7.0 oz.)
ENVIRONMENTAL	
Maximum altitude	21336 m (70000 ft.)
Operating temperature	-55°C to +85°C (-67°F to +185°F)
Storage temperature	-55°C to +85°C (-67°F to +185°F)
Designed to meet these standards	D0-160D DO228 MIL-C-5541 MIL-E-5400 MIL-I-45208A MIL-STD-810 SAE J1455

MECHANICAL DRAWINGS

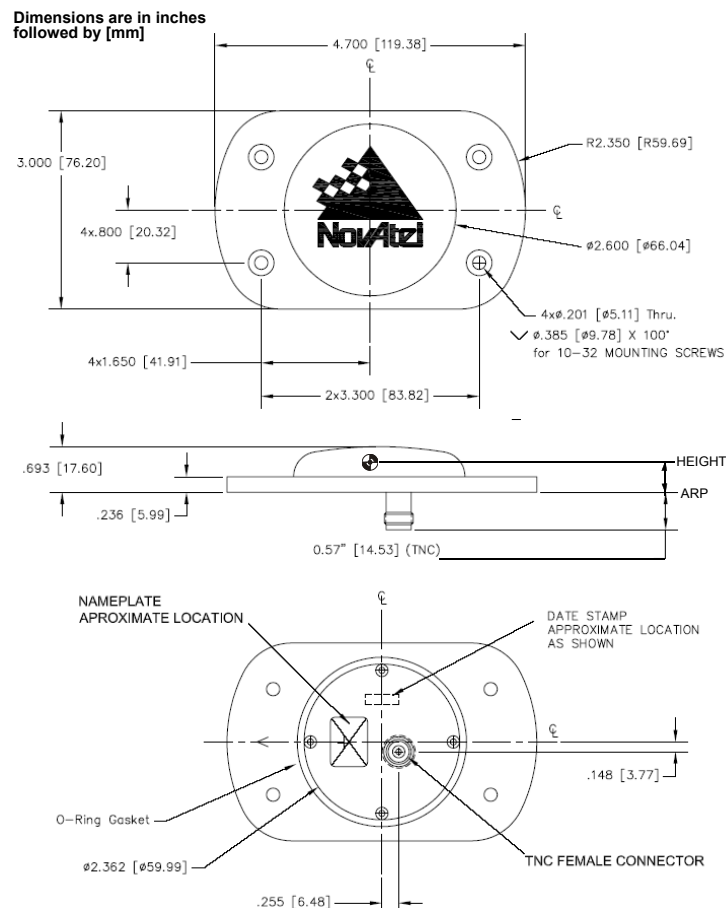

PHASE CENTER

Please refer to the Mechanical Drawings before reading this section.

HEIGHT = Vertical phase center offset from antenna reference point or antenna reference plane (ARP), see the *MECHANICAL DRAWINGS* section of this guide.

For relative offset numbers and phase center variation (PCV) tables, please visit the U.S. National Geodetic Survey (NGS) website at www.ngs.noaa.gov/ANTCAL/.

For absolute offset numbers and to download PCV tables, please visit the GEO++ website at www.geopp.com.

When using either of the websites mentioned above, look for the NovAtel listing of your antenna model **and** its hardware revision.

At the time of print, we are unable to provide typical absolute and relative offset numbers for the current ANT-A72GA-TW-N antenna model. Please check our website for updates to this manual at www.novatel.com/Downloads/docupdates.html and the websites mentioned above.

If you need any further advice on this matter, please visit our website at www.novatel.com. Other methods of contacting Customer Service can be found on the last panel of this guide.

WARRANTY POLICY

NovAtel Inc. warrants that its Global Positioning System (GPS) products are free from defects in materials and workmanship, subject to the conditions set forth below, for the following periods of time:

GPSAntenna™ Modules: One (1) Year
Cables and Accessories: Ninety (90) Days

Date of sale shall mean the date of the invoice to the original customer for the product. NovAtel's responsibility respecting this warranty is limited solely to product repair at an authorized NovAtel location only. Determination of repair will be made by NovAtel personnel or by technical personnel expressly authorized by NovAtel for this purpose.

The foregoing warranties do not extend to

(i) nonconformities, defects or errors in the products due to accident, abuse, misuse or negligent use of the products or use in other than a normal and customary manner, environmental conditions not conforming to NovAtel's specifications, or failure to follow prescribed installation, operating and maintenance procedures, (ii) defects, errors or nonconformities in the products due to modifications, alterations, additions or changes not made in accordance with NovAtel's specifications or authorized by NovAtel, (iii) normal wear and tear, (iv) damage caused by force of nature or act of any third person, (v) shipping damage; or (vi) service or repair of product by the dealer without prior written consent from NovAtel.

In addition, the foregoing warranties shall not apply to products designated by NovAtel as beta site test samples, experimental, developmental, preproduction, sample, incomplete or out of specification products or to returned products if the original identification marks have been removed or altered.

The warranties and remedies are exclusive and all other warranties, express or implied, written or oral, including the implied warranties of merchantability or fitness for any particular purpose are excluded.

NovAtel shall not be liable for any loss, damage or expense arising directly or indirectly out of the purchase, installation, operation, use or licensing of products or services. In no event shall NovAtel be liable for special, indirect, incidental or consequential damages of any kind or nature due to any cause.

There are no user-serviceable parts in the GPSAntenna and no maintenance is required. If the unit is faulty, replace with another unit and return the faulty unit to NovAtel Inc. You must obtain a RETURN MATERIAL AUTHORIZATION (RMA) number by calling NovAtel Customer Service at 1-800-NOVATEL (U.S. and Canada only) or 403-295-4900 before shipping any product to NovAtel or a dealer. Once you have obtained an RMA number, you will be advised of proper shipping procedures to return any defective product. When returning any product to NovAtel, please return the defective product in the original packaging to avoid damage.

Before shipping any material to NovAtel or our Dealer, please obtain a Return Material Authorization (RMA) number from the point of purchase. You may also visit our website (<http://www.novatel.com>) and select *Support | Repair Request* from the side menu.

QUESTIONS OR COMMENTS

If you have any questions or comments regarding your antenna, please contact NovAtel Customer Service using one of the methods provided below.

Email: support@novatel.ca
Web: www.novatel.com
Phone: 1-800-NOVATEL (U.S. & Canada)
403-295-4900 (International)
Fax: 403-295-4901

© Copyright 2002-2009 NovAtel Inc. All rights reserved. Printed in Canada on recycled paper. Unpublished rights reserved under international copyright laws. Recyclable.
OM-20000084 Rev 2 April 20, 2009

